

DESCRIPTION

With 12 bit processing, the technically advanced TVM-821D serial digital waveform monitor/vectorscope for 601 video brings the most commonly needed functions within quick, easy and affordable reach. With elegance and accuracy, the TVM-821D was developed with the operator in mind, incorporating a button-per-function concept. Intelligent design philosophy makes the operation of the TVM-821D intuitively obvious. A unique feature includes an array of LEDs to continually advise the operator of the input signal strength, alerting the user to data errors due to weak signals. A second unique feature is the ability to observe two digital inputs simultaneously. An A and B display (either in parade or overlay) makes routine tasks such as synchronizing, timing and level setting easy to perform. Other functions include LED alarms to alert the operator of EDH, EAV and SAV data problems. Add this to Videotek's long history of making high quality test instruments and the no hassle two year warranty, the TVM-821D is the perfect test solution for editing, production and post production, broadcast and remote vehicles.

Designed for portable applications, the TVM-821D/DC offers all the same features and specifications while operating from a 12 volt DC source.



TVM-821D Back Panel

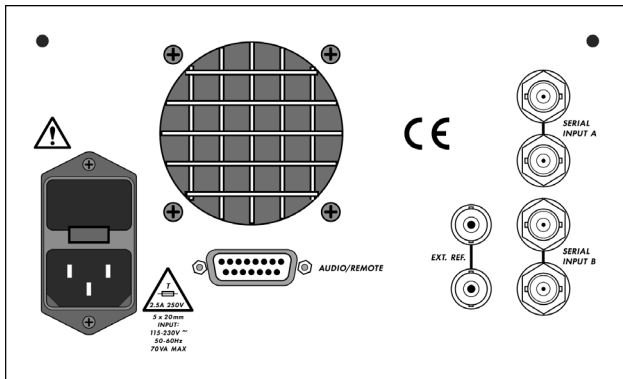

FEATURES

- ▶ Two component serial digital inputs
- ▶ Button and knob per function design
- ▶ Simple operation
- ▶ A/B input "Overlay" mode for easy system timing
- ▶ A/B input "Parade" mode for level comparison
- ▶ LED alarms for EDH, Gamut and Data errors
- ▶ Input EQ display for quick verification of signal integrity
- ▶ Analog audio input with X-Y display for gain and phase measurement
- ▶ RGB or YC_BC_R display
- ▶ Four memories for fast recall of set-ups
- ▶ GPI input for memory recall
- ▶ Looping external analog reference input
- ▶ GPI output for alarm indication
- ▶ Standards available: 525 and 625

TVM-821D/DC Back Panel

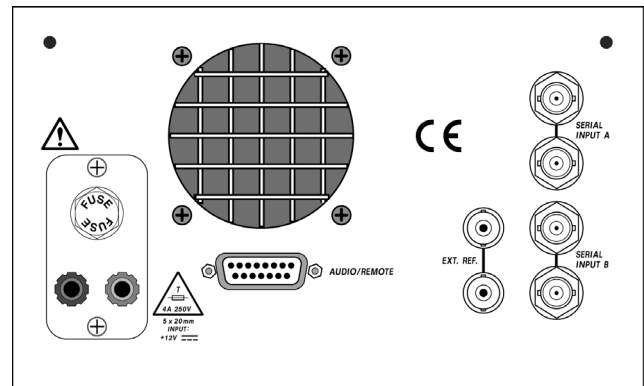

SPECIFICATIONS

Specifications and designs are subject to change without notice.

VIDEO

Inputs:	Two 270 Mb/s 4:2:2 serial digital video conforming to ITU-RBT.601 and SMPTE 259M-C standards
Connectors:	BNC female
Impedance:	Hi-Z loop thru
Return Loss:	≤ -18 dB to 270 MHz
Level:	800 mV p-p
Equalization:	Automatic equalization for a minimum of 200m of 8281

ANALOG REFERENCE

Input:	Composite video, blackburst, or composite sync
Connectors:	BNC female
Impedance:	Hi-Z loop thru
Return Loss:	≤ -40 dB to 5 MHz
Sync Level:	143 mV to 600 mV

SYNCHRONIZATION REQUIREMENTS

Internal Reference:	Derived from serial A or serial B data or free running internal source
External Reference:	External reference will synchronize sweeps

VERTICAL DEFLECTION SYSTEM

Flat:	Y channel to 5 MHz $\leq 2\%$ (± 0.2 dB) C_B C_R channels to 2.5 MHz $\leq 2\%$ (± 0.2 dB)
Low Pass:	3 dB attenuation at 1 MHz. Low pass response (< 10 kHz) within 1% (± 1 dB) of Flat response
Differentiated Step:	For a non-modulated 5 step input with each step being 140 mV $\pm 1\%$, the spikes produced by the filter are 500 to 700 mV. The difference between amplitudes will be less than $\pm 2\%$ of the first spike's amplitude.
Transient Response:	Less than 5 mV of preshoot and/or overshoot at full scale. Flat mode using \sin^2 pulse bar signal
Pulse To Bar Ratio:	0.99:1 to 1.01:1
Tilt - Field Rate Square Wave or Vertical Window Or 25 μ s Pulse Signal:	$\leq 1\%$
Vertical Magnification:	x1 or x5

HORIZONTAL DEFLECTION SYSTEM

Field Rate Time Base:	Equal to x1, x2, or x3 of the field rate of applied video or external reference (User selected Parade modes)
Line Rate Time Base:	Equal to x1, x2, or x3 of the H line rate of applied video or external reference (User selected Parade modes)
Sweep Magnification:	x1 or x10
Timing Accuracy:	1H, HMag (0.5 μ s/div) $\pm 2\%$
Linearity:	2% or less over complete horizontal position range excluding first and last major division

CALIBRATOR

Waveform Mode Frequency:	100 kHz ± 0.1 kHz, synchronizes in H sweep modes providing reference for sweep and magnifier calibration
Amplitude:	700 mV $\pm 0.5\%$
Vector Mode:	Provides vector centering dot

MULTIPLE DISPLAY

MODE MEASUREMENT ACCURACY

Waveform Overlays (H MAG):	± 100 ns - Relative ± 1.5 mV - Relative
Vector Overlays:	± 1.5 mV - Relative

AUDIO

Inputs:	Balanced analog audio, AC coupled
Connector:	15-pin D-sub, female
Impedance:	Approximately 20 k ohms
Level:	0, +4, +8, or +12 dBm internally selectable (factory set to +4 dBm)
Phase Matching:	Less than a trace width separation at 20 kHz
Displays:	Audio may be displayed alone or in any combination with waveform and/or vector

CONTROL

Inputs:	4 Contact closure inputs with common return - Dry Contacts
Connector:	15-pin D-sub (Shared with Audio)
Controls:	Each input will cause a system memory to be recalled. One input per memory
Outputs:	1 Dry Contact Closure consisting of: 1 Normally Open contact 1 Normally Closed contact 1 Common return
Connector:	15-pin D-sub (Shared with Audio)
Controls:	Contact closure will become energized when an EDH, GAMUT, or Data error is detected. Contact will remain energized for 5 seconds

POWER REQUIREMENTS

TVM-821D:

Power Input:	90 to 260 VAC, 50/60 Hz, nominal
Power Consumption:	70 VA

TVM-821D/DC:

Power Input:	10-16 VDC
Power Consumption:	6.5 AMP maximum, operating 20 AMP maximum inrush upon power on
Power Connector:	Dual binding posts

MECHANICAL

CRT:	
Display Size:	8 x 10 cm
Dimensions:	Height: 5.25" (13.34 cm) Width: 8.5" (21.6 cm) Depth: 17.75" (45.1 cm)
Weight:	12 lb (5.45 kg)

ENVIRONMENTAL

Operating Temperature:	0° to 50°C
Storage Temperature:	-40° to 75°C
Humidity:	90% maximum (non-condensing)

STANDARD ACCESSORIES

Operator's Manual
Terminator
Power Cord

OPTIONS

Service Manual	
SSC-1:	Single standard case
PTC-1:	Portable case with extendable sun hood and 20° folding stand
DRC-1:	Double Rackmount Case
BLK-1:	Blank panel for left or right side of DRC-1
DAT -3:	Half-rack tray for DRC-1 to mount any two Videotek modular stand-alone switchers, distribution amplifiers, sync generators, or test signal generators
EPC	EPC European Power Cord
EPC-UK	United Kingdom Power Cord
EPC-AA	Australia Power Cord