

IQD1ADC

Video Analog to Digital Converter

The IQD1ADC converts analog component video (in either YPbPr or GBR formats) to serial 4:2:2 format at 270 Mbit/s. Key channel or Betacam level options available.

Does this module suit your application?

- Analog component YPbPrS or GBRS (selected by links) to serial 4:2:2
- 10-bit resolution
- Key channel versions Y to serial 4:0:0
- Set for SMPTE/EBU N10 levels
- 525 or 625 operation - automatic switching
- Digital clamping for accurate color black
- 'Near' 601 or full Rec. 601 filtering
- EDH insertion as standard
- Out of range indicators for YPbPr
- Level adjustment by RollCall remote control or card edge

Why should you choose this module?

- 10-bit conversion from analog component to digital component video ensures maximum quality
- Full range of options enable conversions for all operational requirements
- Near 601 filter option for monitoring systems
- Digital clamping ensures accurate black levels
- Control by card edge switches or RollCall™ remote control

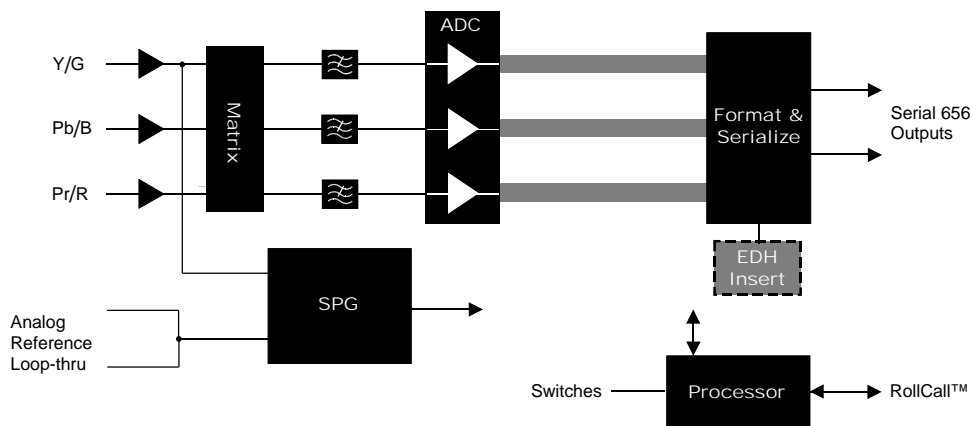

Specifications

Y Frequency Response 601 Filter:- 5.5 MHz \pm 0.05 dB
Near 601 Filter:- 5.5 MHz \pm 0.1 dB

PbPr Frequency Response.. 601 Filter:- 2.75 MHz \pm 0.05dB
Near 601 Filter:- 2.2 MHz \pm 0.1 dB

GBR to YPbPr Matrix Error.. Better than 1%

Signal Input Return Loss..... Better than 40 dB to 6 MHz

Serial Output Level 800 mV \pm 10%

Serial Output Return Loss.... Better than 15 dB to 270 MHz

Jitter < 500 ps

Composite Sync Input 2 V pk to pk \pm 6 dB (loop-through)
525 or 625 line standard

Black Burst Input..... 0.3 V pk to pk \pm 6 dB (loop-through)
525 or 625 line standard

Sync Input Return Loss Better than 40 dB to 6 MHz

Delay 4.26 μ s

Power Consumption

Module Power Consumption 6.3 W max

IQD1ADC

Video Analog to Digital Converter

Order codes for IQH3A/1A enclosures

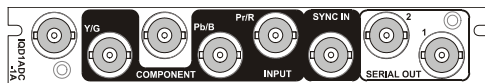

IQD1ADC-1A-10F-0 Video Monitoring ADC.

IQD1ADC-1A-10-E Video ADC Full 601

IQD1ADC-1A-10-B Video ADC Betacam

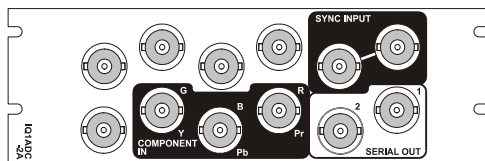

IQD1ADC-2A-10F-0 Video Monitoring ADC.

IQD1ADC-2A-10-E Video ADC Full 601

IQD1ADC-2A-10-B Video ADC Betacam

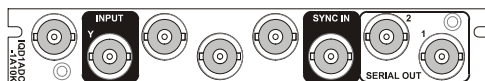

IQD1ADC-1A-10-K Video ADC Key Channel

Order codes for other enclosures

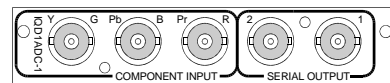

IQD1ADC-1-10F-0 Video Monitoring ADC.

IQD1ADC-1-10-E Video ADC Full 601

IQD1ADC-1-10-B Video ADC Betacam

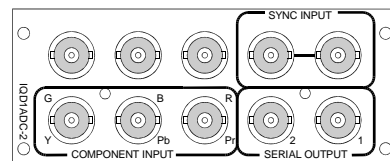

IQD1ADC-2-10F-0 Video Monitoring ADC.

IQD1ADC-2-10-E Video ADC Full 601

IQD1ADC-2-10-B Video ADC Betacam

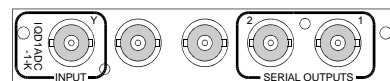

IQD1ADC-1-10-K Video ADC Key Channel

For more details on enclosure types please refer to the Frames/Enclosures section

Inputs & Outputs

Signal Inputs

Component 525/625 YPbPr to EBU/SMPTE specification or GBR

Y 525/625 (-K versions) Y Key signal

Reference Sync Composite Sync or Black Burst

Signal Outputs

Serial 2 sets of 4:2:2 Serial or 4:0:0 for -K versions

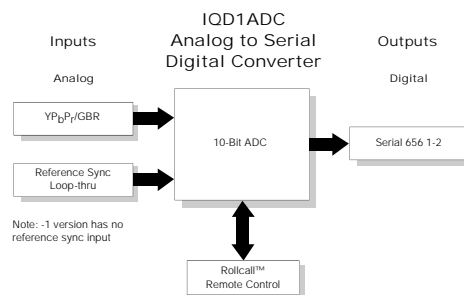

Card Edge & RollCall Controls

Card Edge Controls (also available via RollCall)

Luminance Gain ± 1 dB

Black Level ± 100 mV

PbPr Gain ± 1 dB (not on -K versions)

Sync Select External or Signal Input

VITS Pass (DIGITAL Y output)

On/Off

Input Signal Standard 525/625

Force Standard Auto or Force 525/625

Picture Position -8 to +7 in increments of 74 ns

Functions Available via RollCall™ Only

Y-C Timing ± 592 ns in increments of 74 ns (not on -K versions)